

BOOTH CONSTRUCTION GUIDELINES

SEMCO provides each exhibitor with a back curtain 8 feet in height and two side curtains, each 3 feet in height. A corner booth has only one side drape. An island booth, open on all sides, does not have any pipe and drape. SEMCO provides one identification sign listing the company name and booth number.

Booth displays, including signage, shall not exceed 10 feet in height. Signs exceeding booth height requirements must be approved by show management or exhibitor may be asked to remove. Your display may be 10 feet high for the width of your back drape (this only applies to inline spaces). On each side you will have a 3 feet high side curtain. For inline spaces, your display may remain 10 feet in height from the back wall, up to 5 feet from the aisle, or $\frac{1}{2}$ the depth of your booth (see dotted line below). For the remaining 5 feet, your display must return to the same 3 feet height of the side curtain.

All unfinished portions of displays must be draped or finished so as to be pleasant to the public view. Show Management may require exhibitors to purchase drape if display is not finished adequately. Carpet is strongly recommended.

If your exhibit space is a peninsula, special restrictions apply as indicated by your sales representative. If you have any questions on these restrictions, please call 770.998.9800 and we will be happy to help.

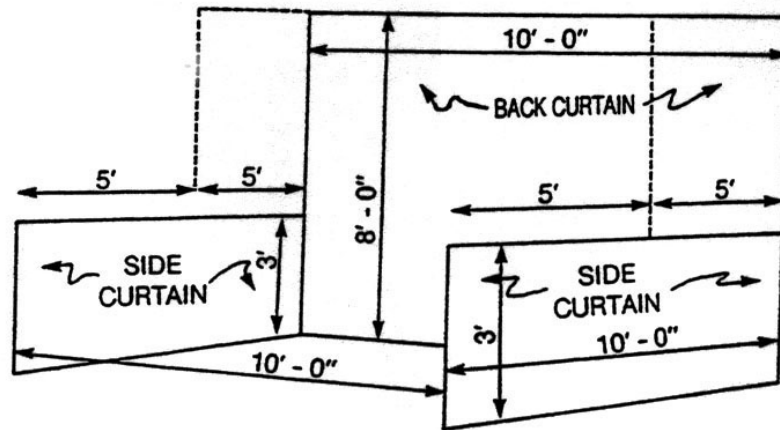

10' Booth

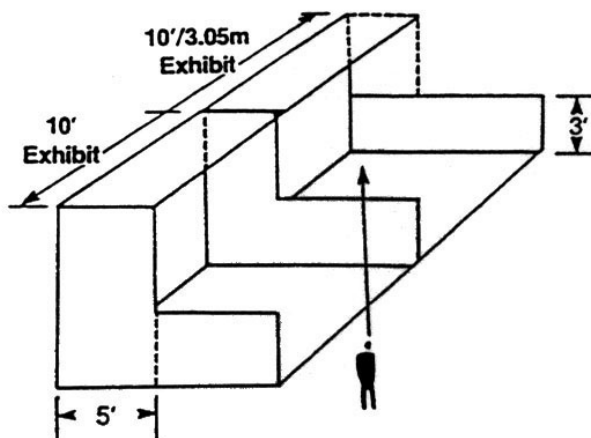

Fire Department Rules and Regulations

No flammable products, open flames, or flammable display materials, etc. are permitted in the exposition hall by order of the Fire Department and the Facility Security Department. Enclosed structures under 300 sq.ft. must have a fire extinguisher and smoke detector. Enclosed structures of over 300 sq.ft. must install a sprinkler system inside the structure. No cartons, boxes, or crates may be stored behind booth curtains. Pine straw is not allowed.